

ecostrad

INSTRUCTION MANUAL

Ecostrad iQ Ceramic Electric Radiator

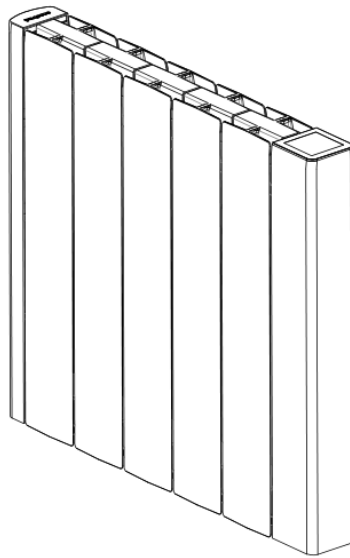

PLEASE READ AND SAVE THESE INSTRUCTIONS



Class II

IPX0



Symbols



Warning

This symbol indicates a hazard with an average risk level which, if not avoided, could result in serious injury or death.



Warning of electrical voltage

This symbol indicates danger to the life and health of persons due to electrical voltage.



Do not cover

This symbol located on the device indicates that it is prohibited to place objects (such as towels, clothes etc.) above or directly in front of the device. To avoid overheating and fire hazards, the device must not be covered.



Hot surface

This symbol located on the device indicates that its surfaces are hot during and immediately after operation. Hot surfaces should not be touched: danger of burns.



Do not spray

This symbol located on the device indicates that it is prohibited to spray the device.



Observe instructions in manual

This symbol located on the device indicates that instructions in the operating manual must be observed when installing and using the device.

Contents

- 1 | Warnings & Precautions
- 2 | Technical Information
- 3 | Installation
 - 3-1 Fixings
 - 3-2 Wall mounting instructions
- 4 | Control Panel
 - 4-1 Power switch
 - 4-2 Display
 - 4-3 Standby mode
 - 4-4 Heating modes
 - 4-5 Settings
 - 4-6 Child lock
 - 4-7 Reset to defaults
- 5 | WiFi Control
 - 5-1 Downloading the app
 - 5-2 Connecting to the app
- 6 | Using the App
 - 6-1 Home overview
 - 6-2 Control interface
 - 6-3 Choose mode
 - 6-4 Setting the program
 - 6-5 Device settings
 - 6-6 Voice integration
- 7 | Troubleshooting
- 8 | Warranty
- 9 | ErP Eco-Design Information
- 10 | Disposal

1 | Warnings & Precautions

Read this manual carefully before using or installing the radiator. Always store the manual in the immediate vicinity of the radiator or its site of use.

Read all safety warnings and all instructions.

Failure to follow the warnings and instructions may result in electric shock, fire, serious injury, or all of the above. Save all warnings and instructions for future reference.



Warning

This appliance can be used by children aged from 8 years and above and persons with reduced physical, sensory or mental capabilities or lack of experience and knowledge if they have been given supervision or instruction concerning the use of the appliance in a safe way and understand the hazards involved. Children shall not play with the appliance. Cleaning and user maintenance shall not be made by children without supervision.

Warning

Children of less than 3 years should be kept away unless continuously supervised. Children aged from 3 years and less than 8 years shall only switch on/off the appliance provided that it has been placed or installed in its intended normal operating position and they have been given supervision or instruction concerning use of the appliance in a safe way and understand the hazards involved. Children aged from 3 years and less than 8 years shall not plug in, regulate, or clean the appliance, or perform maintenance.

Warning

Do not use the device in enclosed spaces if persons are present who cannot leave the room independently and are not under constant supervision.

Warning

In order to avoid overheating, do not cover the radiator.



Warning

In order to avoid a hazard due to inadvertent re-setting of the thermal cut-out, this appliance must not be supplied through an external switching device, such as a timer, or connected to a circuit that is regularly switched on and off by the utility.

Warning

Some parts of this product can become very hot and cause burns. Do not touch the surface when in operation. Do not install close to curtains or other combustible materials. Particular attention should be given where children and vulnerable adults are present.



- Keep the power cable away from all hot parts of the appliance.
- Do not use the device if you detect damage to the mains plug or power cable. If the supply cord is damaged, it must be replaced by the manufacturer, its service agent or similarly qualified persons to avoid a hazard.
- All repairs and servicing must be carried out by a qualified person. To avoid danger any repairs must be completed by the manufacturer, a service agent of the manufacturer or a similarly qualified person.
- Make sure that the voltage indicated on the rating plate for this appliance corresponds to your power outlet.
- The device must not be located immediately below an electrical socket outlet.
- Do not use this device in the immediate surroundings of a bath, shower, swimming pool or any other water container. Risk of electric shock.
- Do not use the device with wet or damp hands.
- No part of the appliance should be submersed in any type of liquid.
- Cleaning should be carried out using a damp cloth only. No abrasive chemicals or materials should be used.
- Never insert fingers or other objects or body parts into the device. Risk of electric shock or injury.
- Do not use any accessories with this device. Use of accessories may cause damage or danger.
- Keep the device at a minimum distance of one metre from curtains and other flammable materials.
- The device must only be installed in an upright and fixed position in accordance with national installation rules.
- The device is for indoor use only.
- Do not use the radiator with a programmer, timer, separate remote control system or any other device that switches the heater on automatically, since a fire risk exists if the heater is covered or positioned incorrectly.
- Make sure the minimum safety distances from walls and objects stated in the installation instructions are observed at all times. This is very important to prevent damage to walls, furniture and soft furnishings and to prevent the product overheating.
- Do not use the device in rooms where contact with flammable or potentially explosive materials like dust, gas or vapour cannot be avoided.
- Do not use in rooms or environments that have a corrosive atmosphere.



- Do not operate the device when wet. If the device gets wet during cleaning, allow it to dry out before using.
- Do not expose the device to water jets.
- Do not transport the device during operation.
- Do not sit on the device.
- Do not overload the socket used to power the device.
- Before carrying out maintenance, care or repair work on the device, ensure the device is unplugged. Do not use the cable to tug the plug from the socket. Hold the plug by its housing and pull.
- Switch the device off and disconnect the power cable from the mains socket when the device is not in use.
- Allow the device to cool down before touching or transporting the device, or attempting maintenance work.
- The device must be placed where the switches and controllers cannot be touched by a person in a bathtub or shower.



2 | Technical Information

Heating element	Ceramic core
Voltage	220-240V AC / 50Hz
Wattage	500W, 1000W, 1500W, 1800W, 2000W
Temperature setting	
Range	7-30 °C
Resolution	0.5 °C
IP rating	IPX0
Appliance class	Class II
Power cable length	1.5m
Motion sensor (5.8G band)	
Operation frequency	5725-5875MHz
Max RF power transmitted	5.28 dBm (3.37mW) < 13.98dBm (25mW)
WiFi frequency (2.4G band)	
Operation frequency	2400-2483.5MHz
Max RF power transmitted	17.21dBm (52.6mW) < 20dBm (100mW)

3 | Installation

3 – 1 | Fixings

Before beginning installation, check that all fixings are supplied. The radiator should only be wall mounted with the manufacturer's fixings.

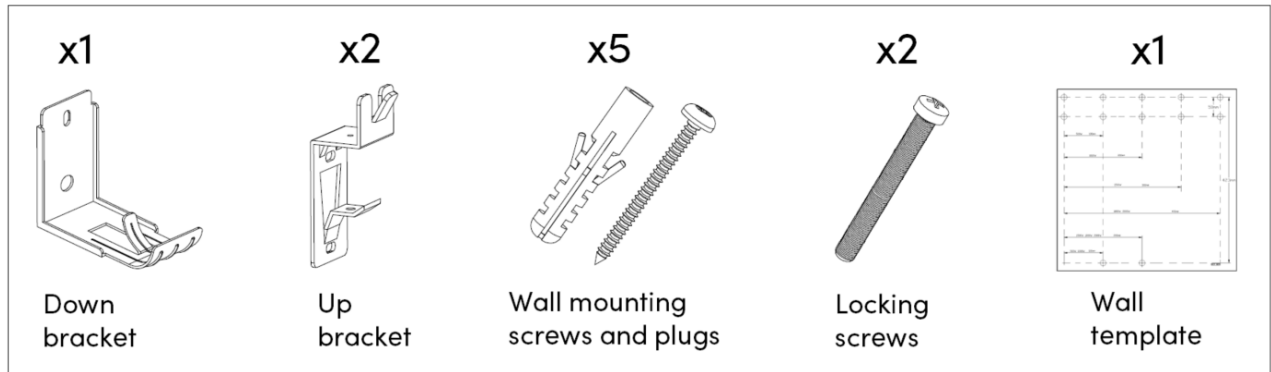

3 – 2 | Wall Mounting Instructions



Warning – Before switching on the appliance make sure that the radiator is correctly fixed and is secure to the wall.

If the device is being fitted in a bathroom, the unit must not be plugged in. The plug should be removed and the unit hardwired into a fused spur. This is a job for a qualified electrician.

1. Choose the mounting position, respecting the minimum distances from surrounding walls, ceilings or fixed objects shown in the diagram below: at least 20cm from the top, 20cm from the sides, 10cm from the floor, and 60cm from the front. Mounting closer than recommended can cause overheating of the device and damage to surrounding objects and surfaces.

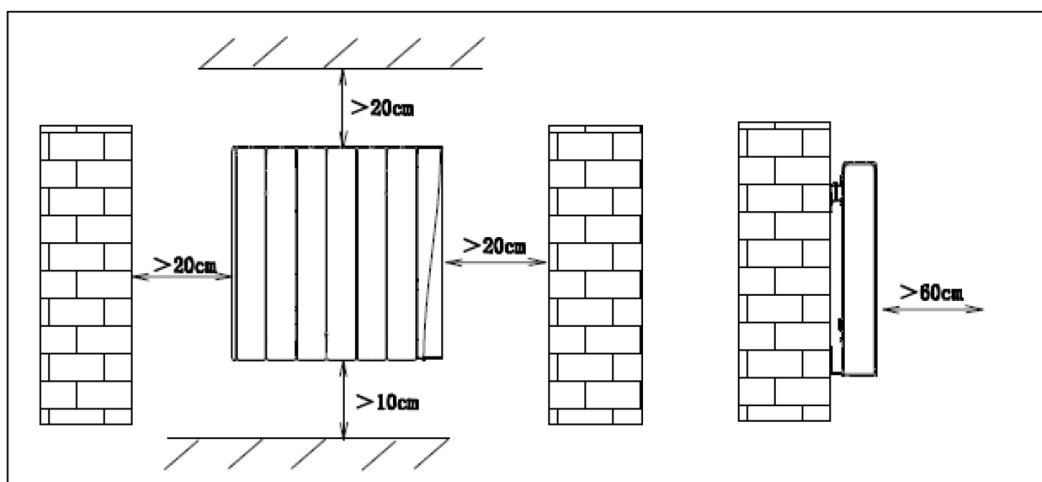

- Using the template, mark the locations of the 5 drill holes required for your product size. Fit the wall plugs into the holes and use the wall mounting screws to fix the brackets in place as per the diagram below.

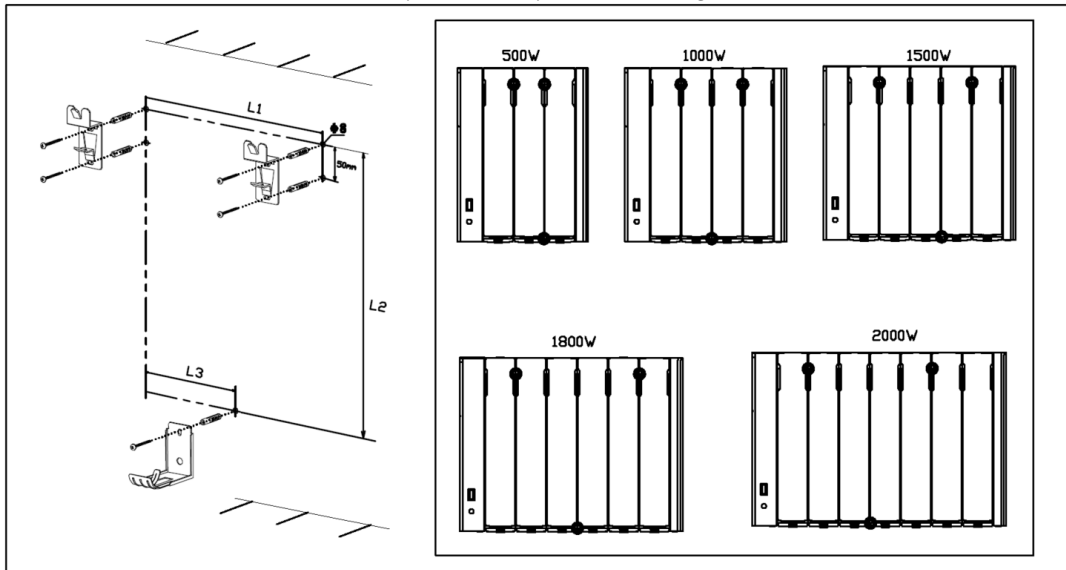

Drill hole distances by product size:

	Model				
Distance	500W	1000W	1500W	1800W	2000W
L1 (mm)	100	200	300	400	400
L2 (mm)	423	423	423	423	423
L3 (mm)	100	100	200	200	200

- Lift up the unit and slide the struts of the upper brackets into the grooves. Then lower the unit so it locks into the lower bracket.

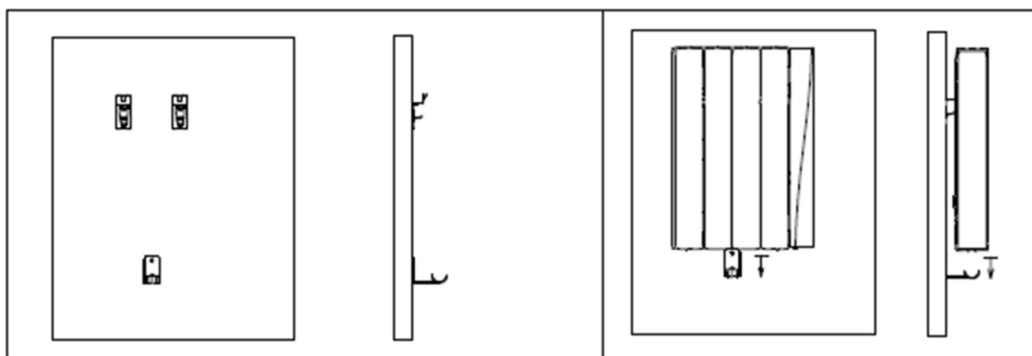

- Secure the unit on the upper brackets by feeding the locking screws into the brackets as below.

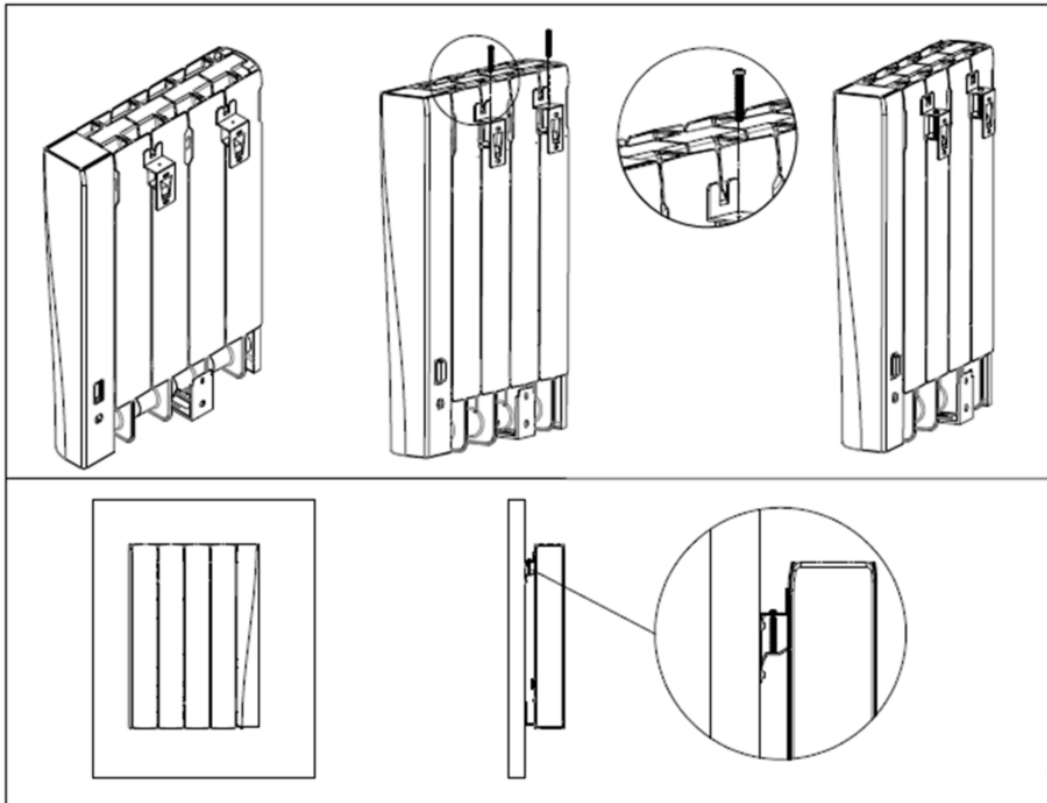

4 | Control Panel

4 – 1 | Power Switch

Before first use, the radiator must be switched on at the mechanical switch at the back of the unit.

This switch must be left in the ON position if you want the radiator to remember its set times and programs.

Memory function

In the event of power failure or disconnection, settings will be saved for approximately 2 hours. If power is restored in that time, the radiator will continue to work as per previous settings. If power is restored after 2 hours, weekly programming, time and working mode will need resetting.

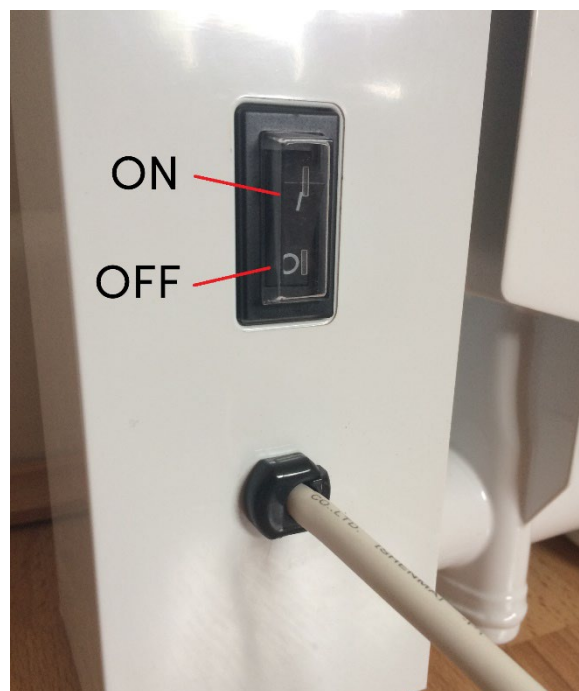

4 – 2 | Display

The touchscreen control panel includes a backlit LCD display. The backlight switches on when the panel is in use and times out after a minute not in use.

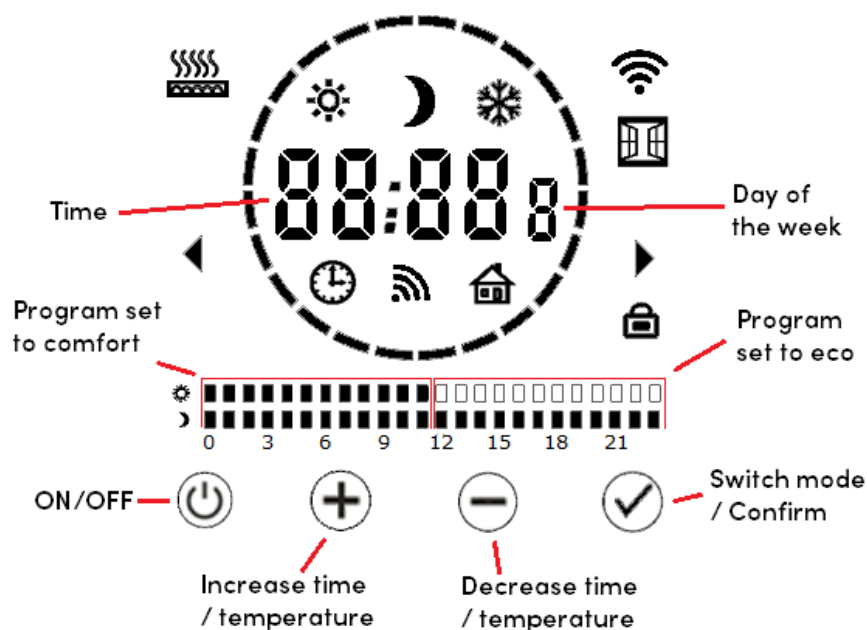

	Comfort
	Eco
	Anti-freeze
	Timer
	Sensor mode
	Pilot wire mode
	Device is heating
	Connected to WiFi
	Open window detected
	Keypad locked

4 – 3 | Standby Mode

When the radiator first switches on it appears in standby mode, where the time is displayed and the radiator will not heat. You can use the button to switch between standby and the heating modes. When the radiator first turns on, the time will appear as 00:00. You can set the correct time in timer mode, see 4-4-4.

4 – 4 | Heating Modes

Tap the button to switch the radiator on. Tap to switch between modes. The icon on the display will change accordingly, browsing through: Comfort , Eco , Anti-Freeze , Timer , Sensor and Pilot Wire mode.

You can also switch back and forth between modes by swiping the touchscreen.

4 – 4 – 1 | Comfort

When the icon (and only the icon) displays on the screen, you are in comfort mode. In this mode, the radiator heats to a constant set temperature. The thermostat measures the room temperature and switches the heating elements on and off accordingly.

The default set temperature is 19 °C. Set temperature can be adjusted using the and buttons. Set temperature range is 7-30 °C.

The temperature set in comfort mode also applies to comfort intervals when they occur in other modes, e.g. program mode and sensor mode (room occupied).

4 – 4 – 2 | Eco 🌙

When the 🌙 icon (and only the 🌙 icon) displays on the screen, you are in eco mode. Just like comfort, on this mode the radiator heats to a constant set temperature. However, eco mode is designed to be set to a lower temperature, providing a low-heat, energy-saving alternative for when you are sleeping or out.

The default set temperature is 15.5 °C. Set temperature can be adjusted using the ⊕ and ⊖ buttons. Set temperature range is 7-30 °C.

The temperature set in eco mode also applies to eco intervals in other modes.

4 – 4 – 3 | Anti-Freeze ❄️

When the ❄️ icon displays on the screen, you are in anti-freeze mode. This is the mode to use when rooms are empty for long periods – for instance, when you go on holiday. Anti-freeze sets the radiator to come on only when temperatures drop low, keeping the room warm enough to prevent pipes from freezing.

Anti-freeze mode is set to 7 °C. This is not adjustable.

4 – 4 – 4 | Timer 🕒

When the 🕒 icon displays on the screen, you are in timer mode. On this mode the radiator will heat as per your set program. You can adjust set time and program from this screen by holding down the ✓ button.

Setting the Time

- Hold down the ✓ button until the hours begin to flash.
- Use the ⊕ and ⊖ buttons to set the hour.
- Press ✓ to confirm. The minutes will begin to flash.
- Use the ⊕ and ⊖ buttons to set the minutes.
- Press ✓ to confirm. The day of the week will begin to flash.
- Use the ⊕ and ⊖ buttons to set the day of the week, where 1 = Monday, 2 = Tuesday and so on.
- Press ✓ to confirm. The display will move to the program setting stage.

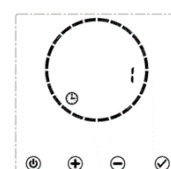
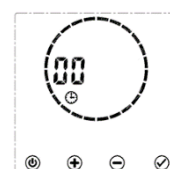

Note – at each stage of the time setting menu, the radiator will automatically jump to the next step if nothing is adjusted in 30 seconds. Once on the program setting screen, the timer will return to timer mode after 30 seconds without activity.

Setting the Program



The timer allows you to set a different program for every day of the week. P1 is the schedule for Monday, P2 is the schedule for Tuesday, and so on. Each program consists of 24 hourly slots where you can set either comfort ☀ or eco 🌙 mode. The radiator will heat at the temperatures you set on comfort and eco mode.

Follow the instructions above for setting the time. When P1 appears on the screen, you are ready to start setting your program:



- P1 and 00 will be on the screen. This means you are choosing a mode for midnight on Monday morning.
- Press **+** to choose comfort ☀ or **-** to choose eco 🌙 mode.
- The bars at the bottom of the screen will change to reflect your choice, and the display will advance to P101 – 1am on Monday.
- Press **+** to choose comfort ☀ or **-** to choose eco 🌙 mode.
- The screen will advance to P102 – 2am.
- Continue pressing **+** and **-** to set comfort ☀ and eco 🌙 modes for the rest of the day. When you get to the end of the day, the time will begin again at 00, midnight. You can go through the program as many times as you need to get it right.
- When you are happy with the program for Monday, press **✓** to move on to Tuesday.
- P2 and 00 will appear on the screen. This means you are choosing a mode for midnight on Tuesday morning. You now have two options:
 - If you want the program for Tuesday to be the same as the day before, hold down the **✓** button until the bars change to match.
 - Alternatively, repeat the steps above to choose modes for each hour.
- Press **✓** to confirm and move on to Wednesday.
- Continue this process until each day of the week is set. Press **✓** to confirm and return to timer mode. The radiator will heat as per your new program.



4 – 4 – 5 | Sensor Mode

When the  icon displays on the screen, the radiator is in sensor mode. In this mode the radiator uses the motion sensor located in the control panel to heat based on whether the room is occupied. The  icon flashes whenever the sensor detects a presence.

When a presence is detected, the radiator heats at comfort temperature . When a presence is no longer detected, the radiator will wait for a set interval of time before stepping down the temperature. This interval is 15, 30, 45 or 60 minutes and can be adjusted in the settings menu – see 4-5-2.

Once the set interval with no presence detected has elapsed, e.g. 45 minutes, set temperature will be reduced by 1 °C. If a further 45 minutes passes with no presence detected, the set temperature reduces by a further degree. After another 45 minutes with no presence detected the radiator switches to the eco set temperature . The radiator holds this temperature for 24 hours. If no presence is detected in this time, the radiator switches to anti-freeze mode .

If at any point in this cycle a presence is detected, the radiator will switch back to its previous state. If a presence is detected in the next 15 minutes, the radiator will switch to the next state up. This continues until the radiator resumes full comfort temperature . This 15 minute interval cannot be adjusted; the adjustable setting affects only the interval the radiator waits when a presence is **not** detected.



4 – 4 – 6 | Pilot Mode

When the  icon displays on the screen, the radiator is in pilot mode. This mode activates external control of the device via a pilot wire (not supplied). Pilot mode enables six externally controlled modes: Comfort, Comfort-1, Comfort-2, Economic, Anti-Frost and Power Off.

This option is tailored to the French market and is not available on the UK model.

4 – 5 | Settings





The settings menu allows you to enable, disable and configure all the radiator's supplementary functions. Temperature compensation (F0), sensor mode (F1), open window detection (F2), WiFi function (F4) and time synchronisation (F5).

Press  to put the radiator into standby mode and hold down  for 5 seconds to enter the settings menu.

4 – 5 – 1 | Temperature Compensation (F0)







The temperature compensation setting allows users to adjust for any discrepancy between the average room temperature and the temperature sensed by the thermostat. For instance, if the temperature in the room is 18 °C, but the radiator is sensing 16 °C, a compensation factor of +2 °C will offset the difference.

The accuracy of the radiator's temperature reading can be affected if the unit is mounted such that the sensor is positioned in a hot or cold spot – such as hot water pipes or a draughty doorway. The sensor is at the bottom right of the unit.



- Press  to put the radiator into standby mode and hold down  for 5 seconds to enter the settings menu.
- F0 will appear on the screen, followed by the current set temperature compensation. Default is 0 °C.
- Use the  and  keys to adjust. Temperature compensation can be adjusted from -5 to 5 °C in steps of 1 °C.
- Press  to confirm and move onto the next setting.



4 – 5 – 2 | Sensor Mode (F1)



This setting controls how long the radiator will wait, when a presence is no longer detected in sensor mode, before dropping to a more energy-efficient mode.

- Press  to put the radiator into standby mode and hold down  for 5 seconds to enter the settings menu.
- Press  to skip through the settings until F1 appears on the screen, followed by the current sensor time interval. The default is 15 minutes.
- Use the  and  keys to choose 15, 30, 45 or 60 minutes.
- Press  to confirm and move onto the next setting.

4 – 5 – 3 | Open Window Detection (F2)







Open window detection is an energy-saving feature designed to cut power to the unit if a window is opened. If the radiator detects a sudden drop in temperature (2 °C or more within 5 minutes), the  icon will appear and the radiator will switch to anti-freeze temperature  to prevent energy wastage as heat escapes through the window. The F2 setting controls how long the radiator waits before switching back to the full set temperature. Open window detection is disabled by default.

- Press  to put the radiator into standby mode and hold down  for 5 seconds to enter the settings menu.
- Press  to skip through the settings until F2 appears on the screen, followed by the current setting. Default is "0" – disabled.

- Use the  and  keys to adjust. Choose 60 or 90 to enable the feature and set the number of minutes, or choose “0” to disable detection.
- Press  to confirm and move onto the next setting.







4 – 5 – 4 | WiFi Function (F4)

This setting allows you to enable or disable the radiator’s connection to WiFi. Disabling the connection is temporary: if you have already added the radiator to your app account, disabling the connection will not remove it. You will be able to control via the app as soon as you re-enable the connection.







- Press  to put the radiator into standby mode and hold down  for 5 seconds to enter the settings menu.
- Press  to skip through the settings until F4 appears on the screen, followed by the current setting. Default is “oF” – disabled.
- Use the  and  keys to adjust. Select “oN” to enable and “oF” to disable.
- Press  to confirm and move onto the next setting.

4 – 5 – 5 | Time Synchronisation (F5)



This setting controls whether the time set on the radiator automatically synchronises with the time on the app when the unit is controlled via WiFi.

- Press  to put the radiator into standby mode and hold down  for 5 seconds to enter the settings menu.
- Press  to skip through the settings until F5 appears on the screen, followed by the current setting.
- Use the  and  keys to adjust. Select “oN” to enable and “oF” to disable.
- Press  to confirm and move onto the next setting.

4 – 6 | Child Lock

Press and hold the  and  keys for 5 seconds to lock the display. The  icon will appear and all keys will be locked except the standby button . Press and hold the  and  keys for 5 seconds to unlock and the  icon will disappear.

4 – 7 | Reset to Defaults

Press  to put the radiator in standby mode. Press and hold the  key for 15 seconds to restore the device to default settings.

5 | Connecting to WiFi

5 – 1 | Downloading the App



The Ecostrad iQ Ceramic is designed to work with the Smart Life app.

Scan the code below to go to the app. Press install and follow the app's instructions to create an account.



NOTE – The Smart Life app is a constantly evolving third party system. This guide was correct at time of printing but may differ slightly from future versions. The app is designed to work on Android or iOS but older software versions may affect app presentation and performance.

5 – 2 | Connecting to the App

1. Ensure WiFi control is enabled in the radiator settings. If the  icon is flashing, WiFi connection is enabled and you can move onto step 2. If the icon is not flashing, go to section 4-4-4 and follow the instructions to enable.
2. To put the radiator in pairing mode, press  to enter standby mode and hold down  until the screen switches to the connection screen. This begins a 180 second count down, giving you 3 minutes to make the connection on the app.
3. On the home page of the app, press + or add device.
4. Select auto scan from the top navigation.

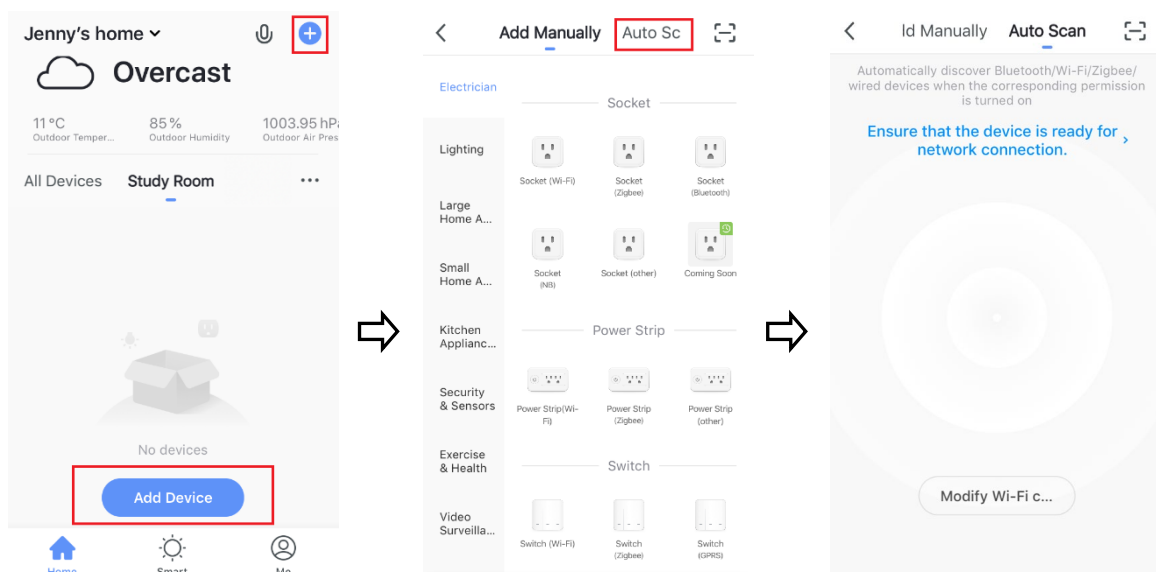

5. The app will demonstrate that it has found the radiator. Press Next.
6. The app will ask you to enter and confirm your WiFi password.

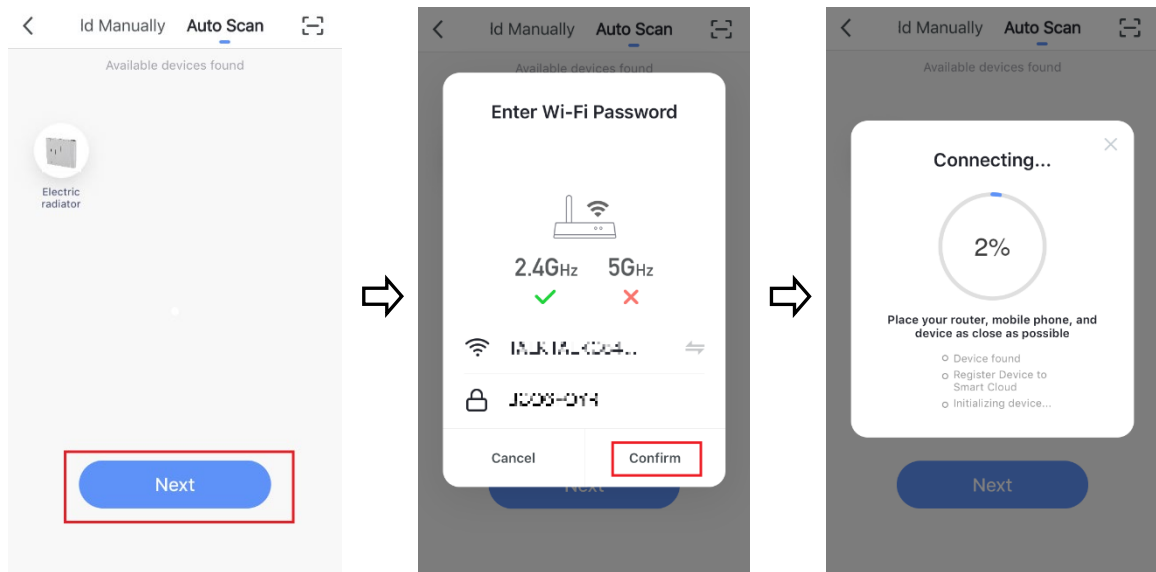

7. The radiator will begin connecting. When it is successfully added, it will appear as below on the app. Press  to change the name of the radiator or Done to return to the home screen.

Troubleshooting

If the radiator does not connect on the first attempt:

- Make sure both the radiator and your smart device are in range of your router.
- Make sure you complete the connection process in 3 minutes. If the 180 seconds has reached the end of its count, begin the process again.
- Ensure your router has a strong internet connection.
- Ensure WiFi is enabled on the radiator.
- Ensure WiFi and Bluetooth are enabled on your smart device.
- Make sure the app has registered successfully.
- Make sure your smart device is connected to the same WiFi network as that to which you are attempting to connect your radiator.
- Ensure you are connected to a 2.4G WiFi band. See instructions within the app if you are currently connected to a 5G band.
- Check any local restrictions on your WiFi. WiFi networks in public places such as hotels and airports may require extra identification steps.

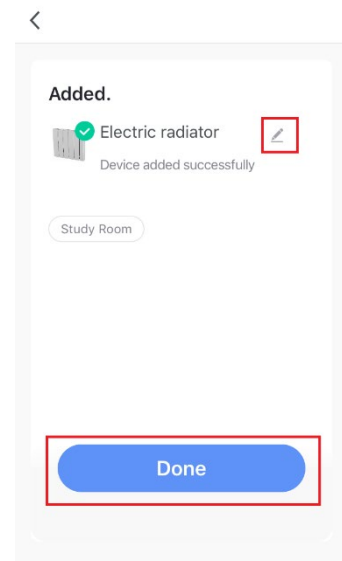

6 | Using the App

NOTE – The Smart Life app is a constantly evolving third party system. The guide below was correct at time of printing but may differ slightly from future versions.

6 – 1 | Home Overview

You can use the Smart Life app to control multiple devices. All devices are displayed on the home screen with their status.

Possible statuses:

- Online
 - Heater will respond to app commands.
- Offline
 - Device is turned off at wall or power switch. It cannot be controlled by the app.

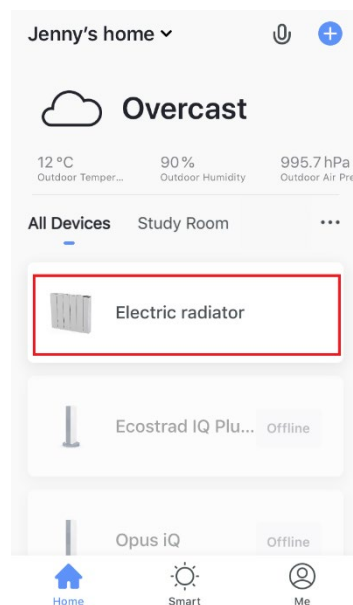

6 – 2 | Control Interface

Tap the heater listing to go to the control interface.

Here you can turn the radiator off and on, adjust set temperatures, choose mode and access weekly programmer and device settings.

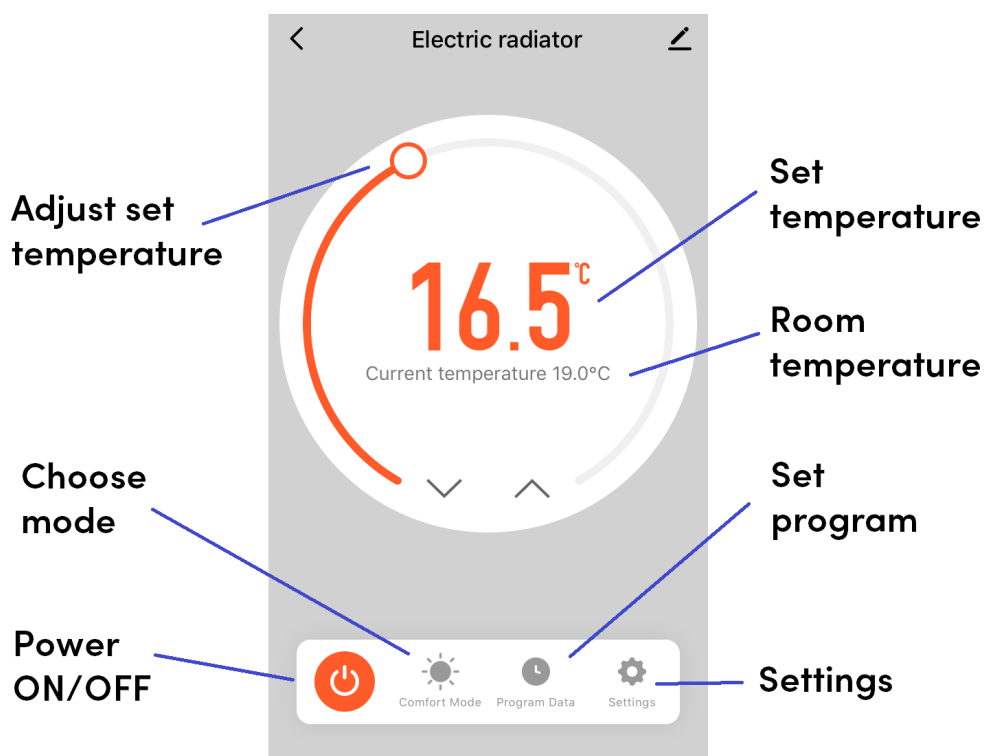

6 – 3 | Choose Mode

Tap the mode icon on the control interface to choose mode. The five options correspond to the five modes on the control panel.

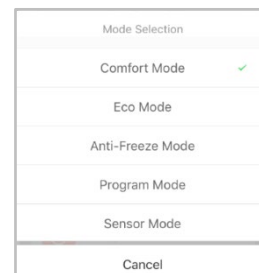

6 – 4 | Setting the Program

Tap the program data icon on the control interface to configure a program.

A program consists of 24 hourly intervals for each day, which you can set to Comfort or Eco temperature.

Tap the interval to choose Comfort (yellow bar) or Eco (green bar). You can drag the start and end times of each mode block to make setting your program quick and easy.

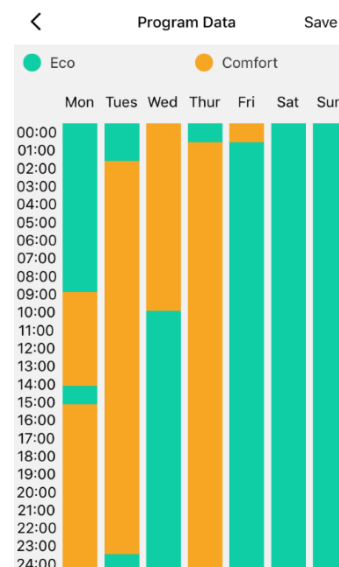

6 – 5 | Device Settings

Tap the icon to view and adjust the radiator's settings. These correspond to the settings available through the control panel.

Tap the icon for settings that relate to the radiator's listing on the app, including its name, any automations it is included in, and the quality of its network connection. Note – the limit function that appears in the settings menu is not available with this model.

6 – 6 | Voice Integration











The Smart Life app is compatible with both Amazon Alexa and Google Home.

To connect Alexa with Smart Life, download the Smart Life skill onto your Alexa app. To connect Google Home with Smart Life, go to "Set up a device" in the Google Home app. Tap "Works with Google" and select Smart Life from the list.

Depending on your device, your voice control app may discover your heaters automatically, or you may need to prompt it to do so. You can find quick guides for both Google Home and Alexa in the Smart Life app's FAQ section.

Make sure you give the heater a name that's easy for you to say and for your voice interface to understand. You can change the radiator's name in the Smart Life app.

Note – the wording of some commands will differ depending on which voice command system you use. See the following table for a full list:

	Command	Action	Notes
	<ul style="list-style-type: none"> • Turn on <device name>. • Switch on <device name>. 	Switches the radiator On.	
	<ul style="list-style-type: none"> • Turn off <device name>. • Switch off <device name>. 	Switches the radiator Off.	
	<p>Alexa</p> <ul style="list-style-type: none"> • Set <device name> to heat. <p>Google Home</p> <ul style="list-style-type: none"> • Set <device name> to hot. 	Switches to Comfort mode.	
	<ul style="list-style-type: none"> • Set <device name> to eco. 	Switches to Eco mode.	
	<p>Alexa</p> <ul style="list-style-type: none"> • Set <device name> to cool. <p>Google Home</p> <ul style="list-style-type: none"> • Set <device name> to cold. 	Switches to Frost mode.	
	<ul style="list-style-type: none"> • Set <device name> to auto. 	Switches to Timer mode.	
°C	<ul style="list-style-type: none"> • Set <device name> to <temperature> degrees. 	In Comfort mode, this changes the set Comfort temperature. In Timer mode, this changes the set temperature of whatever mode is currently running.	Choose value from 7 to 30. This command only has an effect in Comfort or Timer mode.
  °C	<ul style="list-style-type: none"> • Increase <device name> temperature. • Decrease <device name> temperature. • Make <device name> warmer. • Make <device name> cooler. • Raise <device name> temperature. • Lower <device name> temperature. 	Increases or decreases the set temperature by 1 °C, as above.	This command only has an effect in Comfort or Timer mode.
  <x> °C	<ul style="list-style-type: none"> • Increase <device name> <x> degrees. • Decrease <device name> <x> degrees. • Raise <device name> <x> degrees. • Lower <device name> <x> degrees. 	Increases or decreases the set temperature by a number of degrees.	

Room °C	Alexa <ul style="list-style-type: none"> • What's the <device name> temperature? Google Home <ul style="list-style-type: none"> • What temperature is the <device name>? 	Reports the current room temperature sensed by the radiator.	
Unit °C	<ul style="list-style-type: none"> • What temperature is the <device name> set to? 	Reports the set temperature of the radiator.	

7 | Troubleshooting

Problem	Possible Cause	Action
Radiator is not heating. Err1 or Err2 code displaying.	If Err1 is displaying, the thermostat sensor has become disconnected.	The radiator will not heat while either sensor is disconnected. Contact the seller to arrange repair or replacement.
	If Err2 is displaying, the safety cut-out sensor has become disconnected.	

8 | Warranty

The Ecostrad iQ Ceramic carries a 10-year guarantee on the body, a 3-year guarantee on paintwork and a 2-year guarantee on electrical components. Within the stated period, starting from the date the customer receives their unit, Ecostrad guarantee to repair or replace the unit where a fault is due to defects in materials or manufacturing.

The warranty does not cover any defect arising from damage, negligence, usage outside the product's intended purpose or fair wear and tear. The warranty is only valid when the unit has been used at the specified supply voltage, and in accordance with all conditions specified in this manual. The warranty will be void if the heater has been covered, tampered with or opened in any way, or if the ratings label has been removed.

The warranty does not cover failures and faults due to force majeure, accidental damage, mishandling, external impact, chemical agents or atmospheric phenomena, incorrect use of the device, the purchaser's faulty electrical installations, transporting the device or problems caused by the device being handled by persons not authorised by Ecostrad. If the unit has been hardwired, an

invoice may be required to confirm the work was carried out by a qualified professional. Ecostrad cannot accept responsibility for damage, loss or injury caused by incorrect installation, maintenance, cleaning or covering the device.

The warranty is a contract with the original purchaser and does not transfer if the unit is re-sold, gifted or inherited. Proof of purchase, including order number and order confirmation or invoice, will be required if a claim is made.

The warranty covers only the model of heater shown on the purchase invoice. The warranty covers the repair or replacement of the defective product only and Ecostrad shall have no liability for installation costs or consequential losses however incurred. The unit is sold as a DIY product; whilst hardwiring is permitted within the terms of the warranty – provided evidence can be produced that the work was performed by a qualified installer – no compensations will be offered for the installer’s costs in the event of a claim.

Claims must be made with the establishment where the device was purchased. This warranty does not affect the customer’s consumer rights.

9 | ErP Ecodesign Information

Model	500w	1000w	1500w	1800w	2000w
Heat output					
Nominal heat output (P_{nom} / kW)	0.4	0.6	0.8	1.1	1.3
Minimum heat output (indicative) (P_{min} / kW)	N/A	N/A	N/A	N/A	N/A
Maximum continuous heat output ($P_{max.c}$ / kW)	0.4	0.6	0.8	1.1	1.3
Auxiliary electricity consumption					
At nominal heat output (el_{max} / kW)	0	0	0	0	0
At minimal heat output (el_{min} / kW)	0	0	0	0	0
In standby mode (el_{sb} / kW)	0.001	0.001	0.001	0.001	0.001

Information requirements for electrical local space heaters

Item	Unit
Type of heat input, for electric storage local space heaters only (select one)	
manual heat charge control, with integrated thermostat	N/A
manual heat charge control with room and/or outdoor temperature feedback	N/A
electronic heat charge control with room and/or outdoor temperature feedback	N/A
fan assisted heat output	N/A
Type of heat output/room temperature control (select one)	
single stage heat output and no room temperature control	[no]
Two or more manual stages, no room temperature control	[no]
with mechanic thermostat room temperature control	[no]
with electronic room temperature control	[no]
electronic room temperature control plus day timer	[no]
electronic room temperature control plus week timer	[yes]
Other control options (multiple selections possible)	
room temperature control, with presence detection	[yes]
room temperature control, with open window detection	[yes]
with distance control option	[yes]
with adaptive start control	[no]
with working time limitation	[no]
with black bulb sensor	[no]

10 | Disposal



In accordance with WEEE Directive 2012/19/EU, the icon with the crossed-out waste bin on electrical or electronic equipment stipulates that this equipment must not be disposed of with household waste at the end of its life. You will find collection points for free return of waste electrical and electronic equipment in your vicinity. The addresses can be obtained from your local authority.

The separate collection of waste electrical and electronic equipment enables the re-use, recycling and other forms of recovery of waste equipment, and prevents any negative effects for the environment or human health caused by the disposal of hazardous substances potentially contained in the equipment.