

Designer

RCTT

Instruction Guide



HAYERLAND®

Innovators, designers and manufacturers of New Generation Electric Heating



Thank you for choosing Haverland Designer TT radiators.

When installed and programmed in accordance with the guidance of these instructions these Haverland new generation electric radiators provide exceptional comfort and energy savings.

Haverland TT information

Page 2	Energy Saving Information
Page 3	Safety Notes
Pages 4 - 5	Installation
Page 6	Initial Operation
Page 7 - 8	Setting Time / Programming
Page 9	Configuring bespoke times
Page 10	Configuring Economy / Comfort times
Page 11	Important Notes
Page 12	Energy monitoring feature
	Warranty

Energy Saving Information

Haverland Designer TT radiators enable **total** control of Heating requirements in public, general domestic and commercial buildings by individual radiator control for each room or zone.

Energy Saving is achieved by controlling heat in the rooms occupied and avoiding unnecessary heating in vacant rooms and also at times when the room is either infrequently or not in use.

Rooms adjacent to the room where the radiator is located will affect the temperature of the radiator thermostat resulting in a lower temperature reading and increased energy usage if the doors are left open.

Some Haverland models have built in energy monitoring, enabling energy usage to be identified. It is worth noting that a relatively small reduction of just one degree Centigrade can deliver savings.



Safety Notes

Please read these instructions carefully.

The installation should be carried out with consideration to the manufacturer's instructions and in accordance to the relevant National Wiring Regulations. BS7671.

It is important that each radiator has a good Electrical Earth connection.

It is important that the Electrical Ring Main is adequate for the cumulative Wattage of the installation when under maximum Load. If in doubt, contact a qualified electrician to ensure that the electrical supply is satisfactory for the intended use.

Haverland radiators must be firmly and securely fixed to a solid wall and situated well away from any potentially combustible material.

A cable restraint has been installed internally but any strain on the cable should be avoided. The power supply cable should not be allowed to come in direct contact with the radiator whilst it is turned On and Operating. If the cable is or becomes damaged, the unit should not be operated until repaired by a qualified electrician or authorised person.

The radiator must be positioned as described and no less than 15 cm from the Power Socket or an adjacent wall or shelf.

The radiator has been filled with a regulated quantity of Thermal Dynamic media and should not be opened to ensure that absolute safety in use is maintained. The radiator is not designed for any consumer adjustments either pre or post installation.

At the time of disposal the relevant Local Government Department should be notified to determine the correct recycling and disposal procedure.

DO NOT COVER THE APPLIANCE. DO NOT USE TO DRY CLOTHES.

If covered there is a risk of overheating.

The radiator should not be boxed in and consideration should be given to the proximity of any combustible materials and minimum safety distances.

The appliance is not intended for use by persons with reduced physical sensory or mental difficulties or lack of experience or knowledge unless overseen and authorised by a competent and responsible person for their safety.

A built-in programme locking facility is available in the radiator. Please refer to the Programme section.

Children should not be permitted to play with the appliance.

The Warranty will become invalid if the Manufacturer's instructions are not carefully adhered to.

Instructions for installation

It is vital that TT radiators are affixed firmly to a solid constructed and levelled wall.

Make sure that an electrical socket is near where you intend to position the radiator.

A cardboard template is supplied to ensure that the correct height and positioning of the radiator brackets. The four holes in the pattern indicate the precise positions to drill and insert the rawlplug to fix the mounting brackets. Once fixed to the wall it is important to check and ensure the security of the brackets to support the weight of the radiator.

1

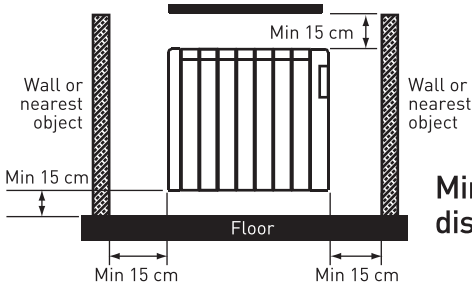

Minimum distances

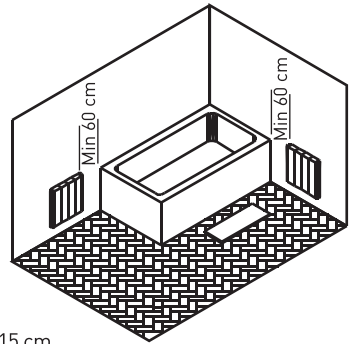

To avoid problems, it is necessary to keep a minimum distance of 15 cm between the radiator and any combustible material.

2

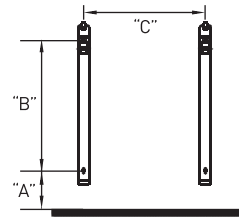

(W)	"A" (mm)	"B" (mm)	"C" (mm)
500	420	246	159
750	420	246	319
1000	420	246	478
1250	420	246	638
1500	420	246	638

Place the template on the floor (follow the instructions on the template) and mark the 4 points in such a way that the 4 positions are marked onto the wall.

Take out the 4 rawlplugs (8 mm) from the bag, the 4 long screws and the two 6x50 mm screws.

Drill four 8 mm diameter holes as marked on the wall and insert the four x 8mm rawlplugs.

Attach the 2 brackets using the 4 long screws as indicated on diagram **Fig 8**.
(Note orientation of brackets in Diagram 4).

Instructions for installation

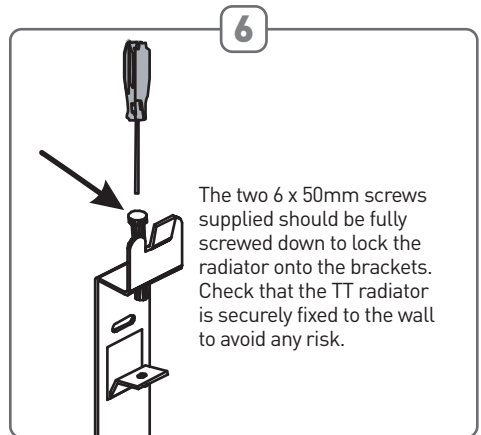
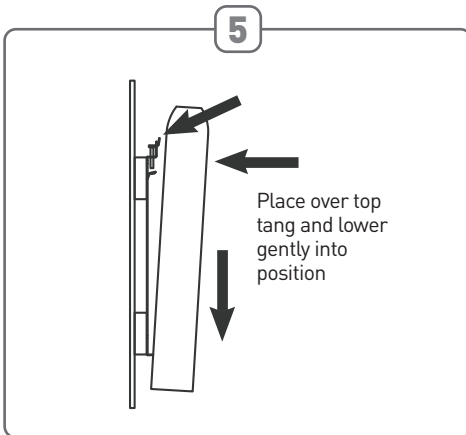
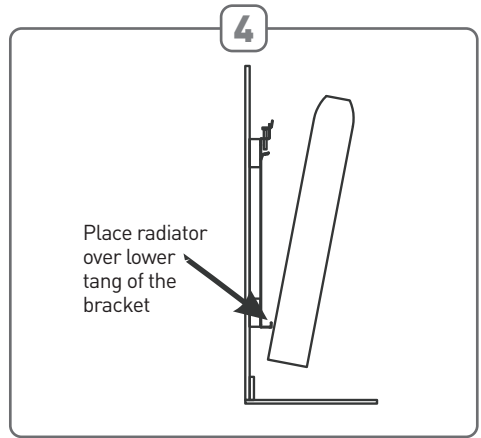
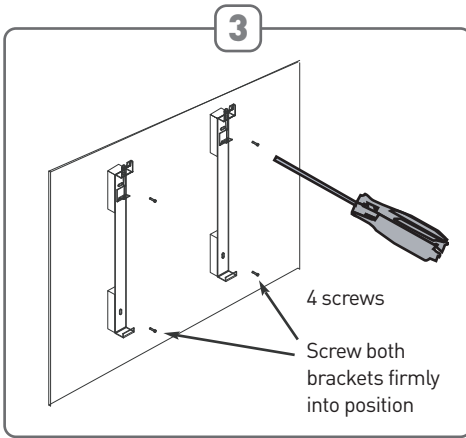

7

To affix the radiator firmly to the brackets:- screw **COMPLETELY** the 6 x 50mm screws in the upper part of the brackets (Diagram 6).

Make sure that the radiator is firmly fixed to the wall to avoid future risk, before connecting the plug into a nearby power supply socket.

INITIAL OPERATION

After securely mounting the radiator as described in the manufacturer's installation instructions, insert the 13 Amp moulded plug into a 13 Amp socket outlet.

Alternatively, ask your electrician to 'hard wire' to a fused connection spur on the main ring circuit.

FEATURES

- Manual programming function
- 7 tamper-proof heating schedules
- 1 bespoke programme option
- Comfort, Economy & Anti-freeze settings
- Weekly programming
- ON/OFF luminous display

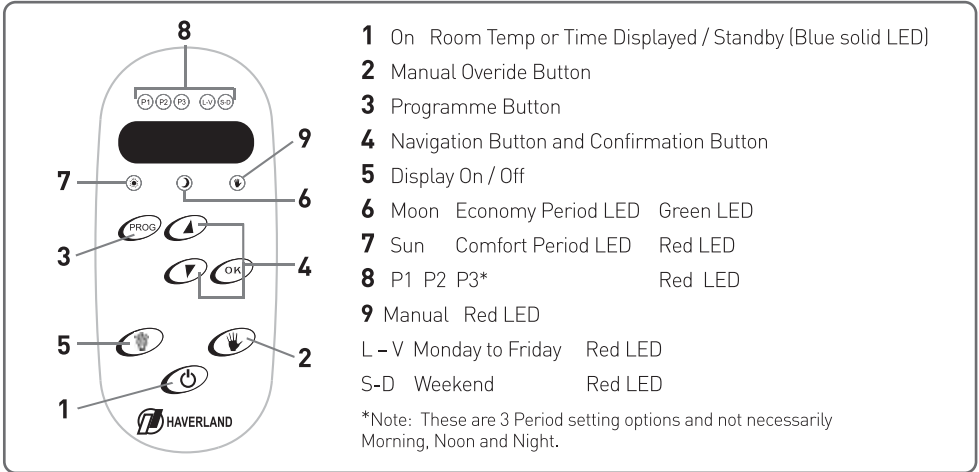

TO START

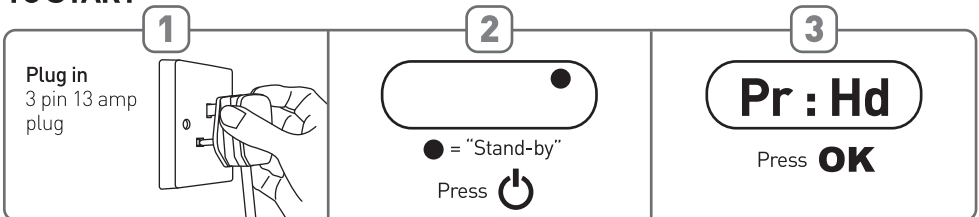

Note: The language in the display is English (by default). You can change the language by pressing the hand button, **Hour** will then appear in the window.

MANUAL MODE

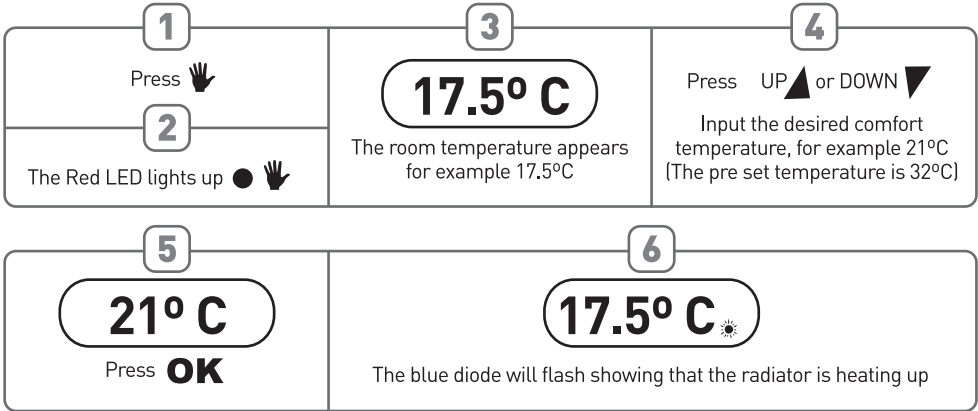

Note: To cancel the Manual override, Press the Hand button again to return to the chosen Plan.

PROGRAMMING OPTIONS

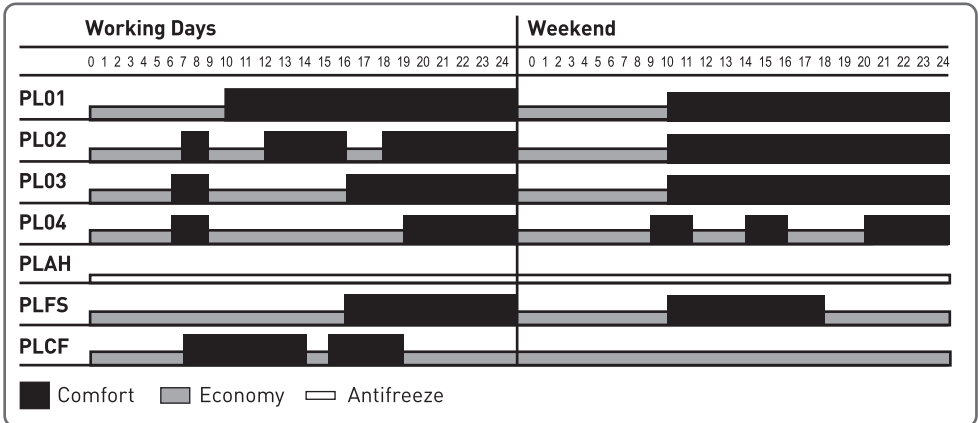

Pre Set Programmes

The Radiator is pre set for **Plan 1** which is General Use and operates from **10:00 am to Midnight** seven days a week.

The **Pre Set Plans** are detailed above. Dependent upon the room occupation you can choose the required Pre Set Plan by scrolling the **PL Plan** and pressing **OK** to confirm.

Should you wish to apply your own Bespoke setting to suit individual requirements during the week Comfort i.e. starting at **06:00** and **Economy** at **08:00** Monday to Friday it is necessary to use the **PLCF bespoke setting**.

To programme times to suit your own preferences you have to use the CF Plan (**PLCF**)

When the radiator is turned **ON** and the **Date and Time Set** you will see the current room temperature in the window i.e. **17.5°C**.

<p style="text-align: center;">1</p> <p style="text-align: center;">Programming the hour</p> <p style="text-align: center;">-00:00</p> <p style="text-align: right;">Press ▲ or ▼ Press OK</p>	<p style="text-align: center;">2</p> <p style="text-align: center;">Programming the minutes</p> <p style="text-align: center;">00:00-</p> <p style="text-align: right;">Press ▲ or ▼ Press OK</p>
<p style="text-align: center;">3</p> <p style="text-align: center;">day</p> <p style="text-align: right;">Press OK</p>	<p style="text-align: center;">4</p> <p style="text-align: center;">Programme the current day of the week</p> <p style="text-align: center;">dd no</p> <p style="text-align: right;">Press ▲ or ▼ no = Mon Press OK tu = Tues ue = Wed</p>
<p style="text-align: center;">5</p> <p style="text-align: center;">t° C</p> <p style="text-align: right;">☀ Press OK</p>	<p style="text-align: center;">6</p> <p style="text-align: center;">Mark the desired comfort temperature</p> <p style="text-align: center;">21° C</p> <p style="text-align: right;">Press ▲ or ▼ then Press OK at the desired temp.</p>
<p style="text-align: center;">7</p> <p style="text-align: center;">t° E</p> <p style="text-align: right;">☾ Press OK</p>	<p style="text-align: center;">8</p> <p style="text-align: center;">Mark the desired economy temperature</p> <p style="text-align: center;">14° C</p> <p style="text-align: right;">Press ▲ or ▼ then Press OK at the desired temp.</p>
<p style="text-align: center;">9</p> <p style="text-align: center;">PLAn</p> <p style="text-align: right;">Press OK</p>	<p style="text-align: center;">10</p> <p style="text-align: center;">Choose the programme or plan you desire</p> <p style="text-align: center;">PL 01</p> <p style="text-align: right;">Press ▲ or ▼ Press OK</p>
<p style="text-align: center;">11</p> <p style="text-align: center;">Press PROG to put the plan into action</p>	

Note: The Economy period is the low heat, If the room is vacant, set this to a Low temperature to avoid unnecessary heating.

HOW TO CONFIGURE A PLAN FOR YOUR SPECIFIC REQUIREMENTS

If none of the 7 pre set programmes match your heating requirements, here is an example of how you can configure your own bespoke heating programme.

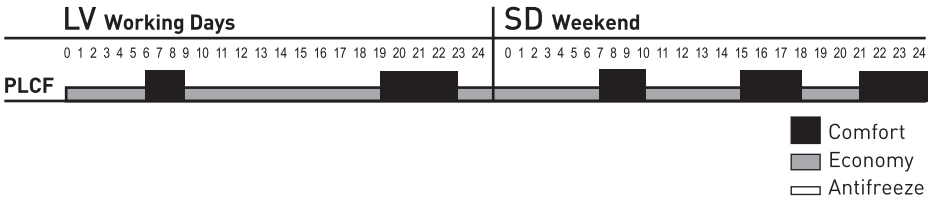

1

Press **PROG** for 2 seconds

2

Hour

Press ▲

3

PLAN

Press **OK**

4

Choose the programme or plan **PLCF**

PLCF

Press ▲ or ▼

5

Press **OK**

Now we are going to introduce the start of the first **Comfort** period from Monday to Friday. The **Comfort** first period **P1** and the days **LV** Monday to Friday LED's will light up. In our case, the **Comfort** period starts at 6.00

1

Press ▲ or ▼

Choose 06.00



06 : 00



2

Press **OK**

Now we are going to introduce the start of the first **Economy** period from Monday to Friday.
The **Economy** first period **P1** and the days **LV** Monday to Friday LED's will light up.
In our case, the **Economy** period starts at 09.00

1

Press ▲ or ▼

Choose 09.00

09 : 00

Press **OK**

Now we are going to programme period **P2**

2

Press ▲ or ▼

Choose 14.00

Comfort

14 : 00

Press **OK**

3

Press ▲ or ▼

Choose 18.00

Economy

18 : 00

Press **OK**

Now we are going to programme period **P3**

4

Press ▲ or ▼

Choose 20.00

Comfort

20 : 00

Press **OK**

5

Press ▲ or ▼

Choose 24.00

Economy

24 : 00

Press **OK**

Now if you wish, you can programme weekend period (Saturday and Sunday) = **SD**

When you finish programming, press **PROG**

The room temperature will appear on the display.

You have now programmed the heating system plan.

IMPORTANT



If you want only one period i.e. 08.00 Comfort until 17.00 Economy, this must be set at Period 1. Period 2 and Period 3 must be set at 00.00 for Comfort and Economy. Alternatively two periods P1 07.00 - 09.00 P2 17.00 - 21.00. Period 3 must be 00.00.

If you do not wish to programme P2 or P3 period, you must put the hour of this period at "00:00". As you can see, we have not defined a third period between Saturday and Sunday.



SWITCHING OFF THE DISPLAY

To switch off the display - press the button 

If you wish to illuminate the display again, press any search button  

This option is cancelled when the radiator is programmed in the anti-freeze plan "PLAH".

HOW TO LOCK IN YOUR HEATING PROGRAMMES

To activate the programme locking function, touch simultaneously for two seconds (Fig. 1); and again To deactivate the locking function, touch simultaneously the keys (Fig. 2)



Fig. 1



Fig. 2

STAND-BY MODE

This mode will freeze the programme until pressed again when the programme will resume

Press 



● = "Stand-by"
constant blue diode

DISCONNECTING THE RADIATOR

If the switch-off time exceeds **24 hours**, the current date and time will have to be re-programmed

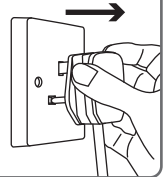

MAINTENANCE

It does not need any special maintenance

Dust with a dry, soft cloth when the radiator is disconnected and cold

Never use solvents or abrasive products

It is best to clean the surface of the radiator at the beginning of the heating season (**always before disconnecting it**).

ENERGY MONITORING

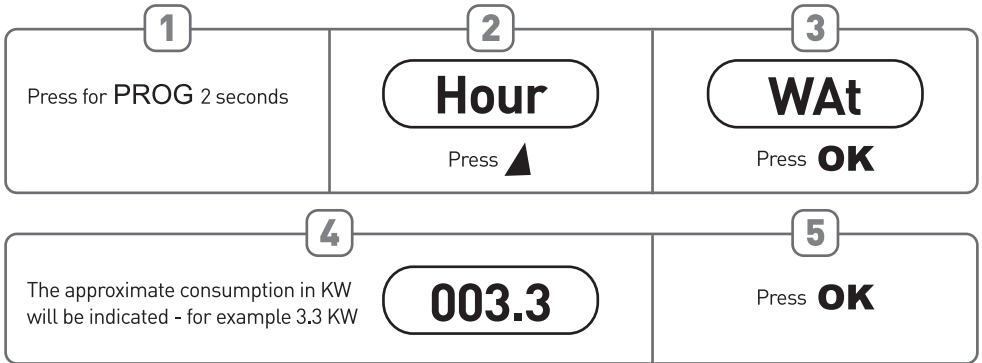

Note: if you wish to reset the counter, repeat steps 1-4 and Press ▼ for 3 seconds.
The counter will automatically reboot every 30 days.



HAVERLAND®

Innovators, designers and manufacturers of New Generation Electric Heating

Haverland UK Limited
The Mill House, Easton Royal, Marlborough, Wiltshire SN9 5LU
Customer Service Telephone: 01672 811940
Fax: 01672 811944
email: heat@haverland.co.uk
www.haverland.co.uk



RCTT WARRANTY

Date of purchase

Day

Month

Year

Name of your supplier

Town / City

Your name

Address

Post code

Telephone

email

Product code



Customer service telephone: **01672 811940**

RCTT GUARANTEE



1. Haverland guarantees against material, design or manufacturing faults at the moment of its original acquisition and it also guarantees for 2 years, the electronic components and paintwork/finish for 3 years and lifetime for the aluminium body (exclude accidental damage, transport, and misuse).
2. If, during the guarantee period, the product were to become faulty and this is due to a design fault or a fault in the material or the manufacturing, Haverland will repair or replace the product, whichever it deems appropriate, under the conditions stipulated below:
 - 2.1. The guarantee is only valid if the original Guarantee Certificate issued by the distributor or installer to the purchaser is presented and when the aforementioned guarantee stipulates the series N^o and model of the product (shown on the technical characteristics sticker) and date of purchase. HAVERLAND reserves the right to refuse the guarantee service if this information has been removed or modified after the original purchase of the product. The receipt or original invoice will only be accepted as a proof of purchase when presented to the distributor or installer who sold the product.
 - 2.2. The guarantee only applies to the cases relative to material, design or manufacturing faults; under no circumstances does it cover damage to the radiator due to the following:
 - 2.2.1. Incorrect use of the product for purposes that are not normal or without respecting instruction manuals as to the use and maintenance of the product, as well as the installation or use of the product in a way that does not comply with the technical safety standards in force.
 - 2.2.2. Repairs performed by unauthorised service workshops or the opening of the radiator by unauthorised persons.
 - 2.2.3. Unforeseen accidents that are out of Haverland's control, such as lightning, fires, floods, public disturbances, etc.
 - 2.2.4. The repairs or replacements covered by this guarantee do not allow the extension or new start up of the guarantee period.
 - 2.2.5. Faulty pieces or components removed, remain the property of Haverland.
 - 2.2.6. This guarantee does not affect the purchaser's legal rights set forth by the national legislation in force, or the purchaser's rights against those of the distributor or installer that could arise from the sale contract.
 - 2.2.7. In the absence of an applicable national legislation in force, this guarantee will serve to be the purchaser's only protection. Haverland, its offices and distributors and installers will not be held responsible for any kind of damages, either fortuitous or accidental derived infringing any implicit regulation related to this product.
3. If you have to evoke the guarantee, take the radiator to the distributor / installer where you acquired it. In the case of problems, Haverland places the **Technical Assistance Telephone Number** at their clients' disposal: **01672 811940** as well as the email address: heat@haverland.co.uk



HAVERLAND®

Innovators, designers and manufacturers of New Generation Electric Heating

Haverland UK Limited
The Mill House, Easton Royal, Marlborough, Wiltshire SN9 5LU
Customer Service Telephone: 01672 811940
Fax: 01672 811944
email: heat@haverland.co.uk
www.haverland.co.uk